

***THIS DOCUMENT IS FOR MAINTENANCE
PURPOSES ONLY AND IS NOT
RECOMMENDED FOR NEW DESIGNS***

SP8680A

550MHz ÷ 10/11

The SP8680A is an ECL variable modulus divider, with ECL and TTL compatible outputs. The circuit can operate from either ECL or TTL supplies. It divides by 10 when either of the ECL control inputs, $\overline{PE1}$ or $\overline{PE2}$, is in the high state and by 11 when both are low (or open circuit). The divider can be set asynchronously to the eleventh state by applying a high level to the master set (MS) input.

FEATURES

- Very High Speed – 650MHz (Typ.)
- ECL and TTL Compatible Inputs/Outputs
- DC or AC Clocking
- Clock Inhibit
- Asynchronous Master Set
- Equivalent to Fairchild 11C90

QUICK REFERENCE DATA

- Supply Voltage: –4.75V to –5.5V (ECL),
4.75V to 5.5V (TTL)
- Power Consumption: 420mW
- Temperature Range: –55°C to +125°C

ABSOLUTE MAXIMUM RATINGS

Supply voltage, $ V_{CC} - V_{EE} $	8V
ECL output source current	50mA
Storage temperature range	–65°C to +150°C
Max. junction temperature	+175°C
TTL output sink current	30mA
Max. clock input voltage	2.5V p-p

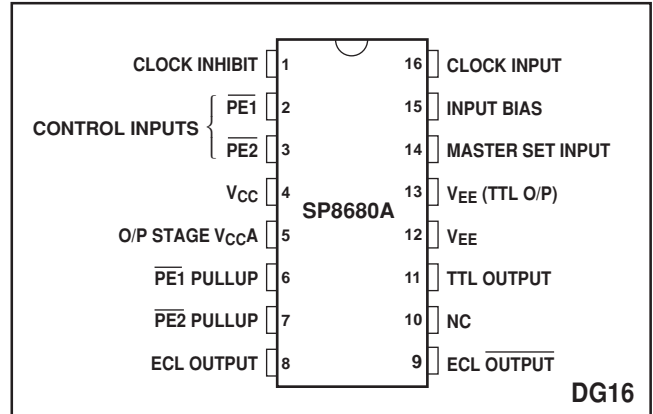

Fig. 1 Pin connections - top view

ORDERING INFORMATION

SP8680 A DG

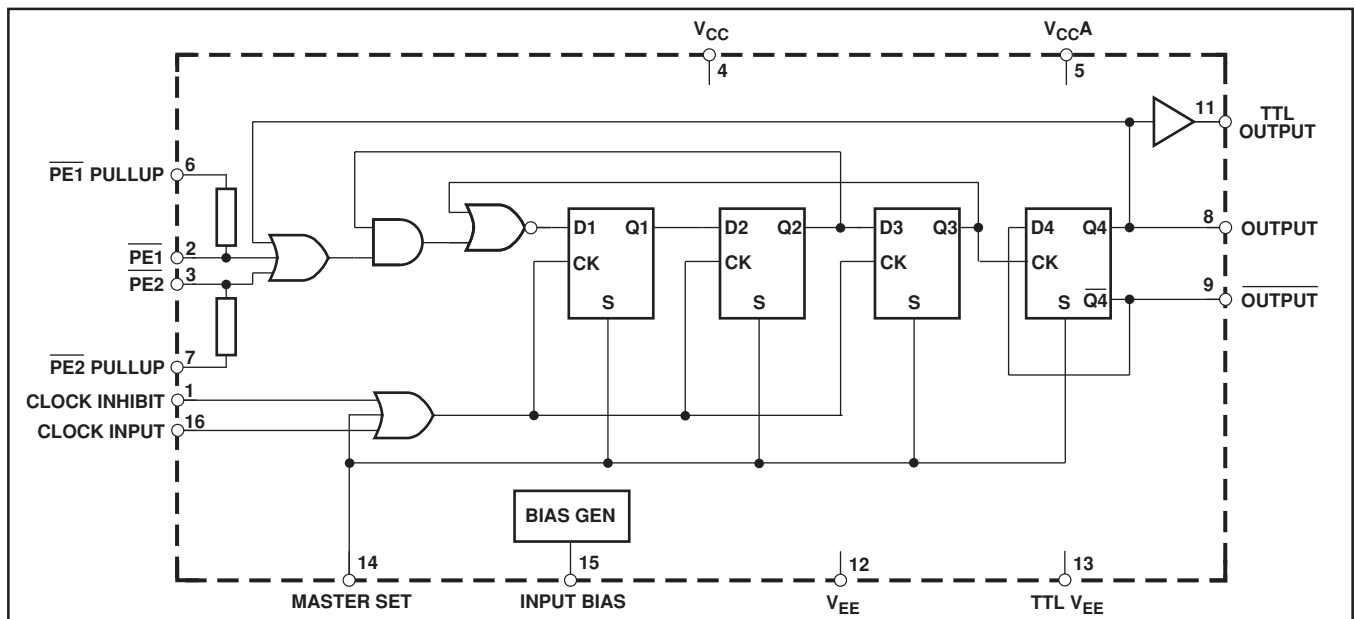

Fig. 2 Functional diagram

SP8680A

ELECTRICAL CHARACTERISTICS

Unless otherwise stated, the Electrical Characteristics are guaranteed over specified supply, frequency and temperature range

ECL OPERATION

Supply voltage, $V_{EE} = -4.75V$ to $-5.5V$, $V_{CC} = 0V$
 Temperature, $T_{AMB} = -55^{\circ}C$ to $+125^{\circ}C$

Characteristic	Symbol	Value		Units	Conditions	Notes
		Min.	Max.			
Maximum frequency (sinewave input)	f_{MAX}	550		MHz	AC coupled clock = 350mV p-p	5
Minimum frequency (sinewave input)	f_{MIN}		10	MHz	AC coupled clock = 600mV p-p	6
Power supply current	I_{EE}		105	mA	$V_{EE} = -5.5V$, pins 6, 7, 13 o/c	5
ECL output high voltage	V_{OH}	-0.93	-0.78	V	$V_{EE} = -5.2V$ (25°C), $R_L = 100\Omega$ to $-2V$	
ECL output low voltage	V_{OL}	-1.85	-1.62	V	$V_{EE} = -5.2V$ (25°C), $R_L = 100\Omega$ to $-2V$	
Input high voltage	V_{INH}	-0.095	-0.81	V	$V_{EE} = -5.2V$ (25°C)	
Input low voltage	V_{INL}	-1.85	-1.475	V	$V_{EE} = -5.2V$ (25°C)	
Input low currents	I_{IL}	0.5		μA	25°C	
Input high current, clock and MS	I_H		400	μA	$V_{IN} = -1.85V$ (25°C)	
Input high current, <u>PE1</u> and <u>PE2</u>	I_H		250	μA	$V_{IN} = -0.8V$ (25°C)	
Propagation delay, clock to Q4 low	t_{pHL}		4	ns	$R_L = 100\Omega$ to $-2V$ (25°C)	6
Propagation delay, clock to Q4 high	t_{pLH}		3	ns	$R_L = 100\Omega$ to $-2V$ (25°C)	6
Propagation delay, MS to Q4 high	t_{pLH}		6	ns	25°C	6
Modulus control set-up time	t_s	4		ns	25°C	3, 6
Modulus control release time	t_r	4		ns	25°C	4, 6
ECL output rise time (20% - 80%)	t_{ELH}		2	ns	25°C	6
ECL output fall time (80% - 20%)	t_{EHL}		2	ns	25°C	6

TTL OPERATION

Supply voltage, $V_{CC} = V_{CCA} = 4.75V$ to $5.5V$, $V_{EE} = 0V$
 Temperature, $T_{AMB} = -55^{\circ}C$ to $+125^{\circ}C$

Characteristic	Symbol	Value		Units	Conditions	Notes
		Min.	Max.			
Maximum frequency (sinewave input)	f_{MAX}	550		MHz	AC coupled clock = 350mV p-p	5
Minimum frequency (sinewave input)	f_{MIN}		10	MHz	AC coupled clock = 600mV p-p	6
Power supply current	I_{CC}		111	mA	$V_{CC} = 5.5V$, pins 6, 7 o/c, pin 13 to pin 12	5
TTL output high voltage	V_{OH}	2.3		V	$V_{CC} = 4.75V$, $I_{OH} = -640\mu A$	5
TTL output low voltage	V_{OL}		0.5	V	$V_{CC} = 5.5V$, $I_{OL} = -20\mu A$	5
Input high voltage, <u>PE1</u> and <u>PE2</u>	V_{INH}	3.9		V	$V_{CC} = 5.0V$ (25°C)	
Input low voltage, <u>PE1</u> and <u>PE2</u>	V_{INL}		3.5	V	$V_{CC} = 5.0V$ (25°C)	
Input low current, <u>PE1</u> and <u>PE2</u>	I_{IL}	-4		mA	$V_{CC} = 5.5V$ (25°C), pins 6, 7 = V_{CC} , $V_{IN} = 0.4V$	
Propagation delay, clock to TTL low	t_{pHL}	6	14	ns	$V_{CC} = 5.0V$ (25°C)	6
Propagation delay, clock to TTL high	t_{pLH}	6	14	ns	$V_{CC} = 5.0V$ (25°C)	6
Propagation delay, MS to TTL high	t_p		17	ns	$V_{CC} = 5.0V$ (25°C)	6
Modulus control set-up time	t_s	4		ns	$V_{CC} = 5.0V$ (25°C)	3, 6
Modulus control release time	t_r	4		ns	$V_{CC} = 5.0V$ (25°C)	4, 6
TTL output rise time (20% - 80%)	t_{TLH}		5	ns	$V_{CC} = 5.0V$ (25°C)	6
TTL output fall time (80% - 20%)	t_{THL}		5	ns	$V_{CC} = 5.0V$ (25°C)	6

NOTES

- The temperature coefficients of $V_{OH} = +1.2mV/^{\circ}C$, $V_{OL} = +0.24mV/^{\circ}C$ and of $V_{IN} = +0.8mV/^{\circ}C$.
- The test configuration for dynamic testing is shown in Fig.6.
- The set-up time t_s is defined as the minimum time that can elapse between L→H transition of control input and the next L→H clock pulse transition to ensure that the ÷ 10 mode is obtained.
- The release time t_r is defined as the minimum time that can elapse between H→L transition of control input and the next L→H clock pulse transition to ensure that the ÷ 11 mode is obtained.
- Tested at +25°C and +125°C only.
- Guaranteed but not tested.

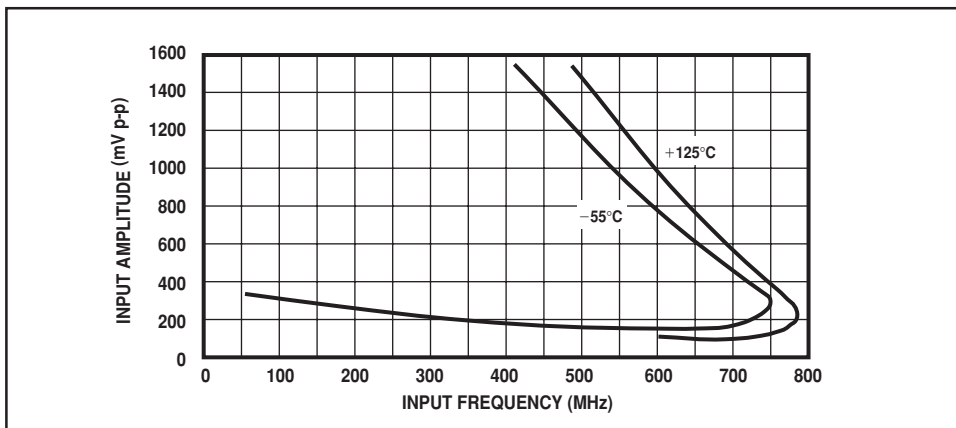

Fig. 3 Typical input sensitivity

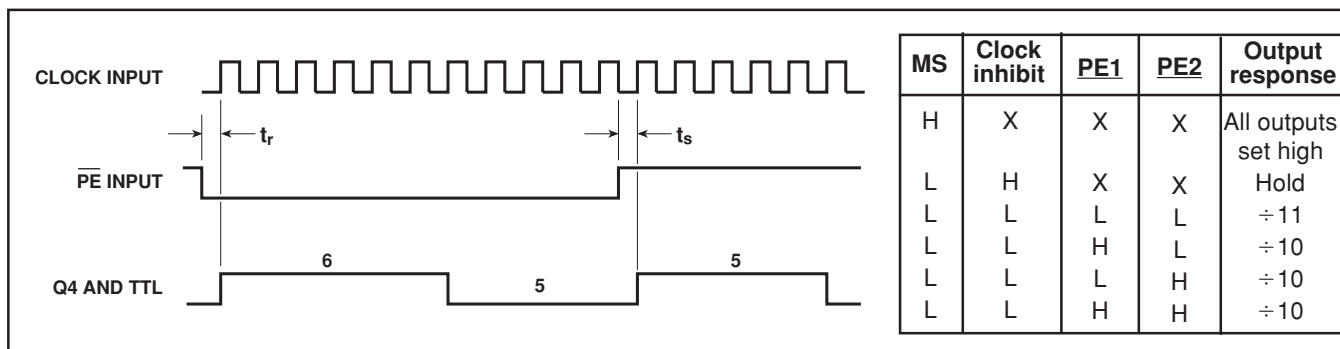

Fig. 4 Truth table and timing diagram

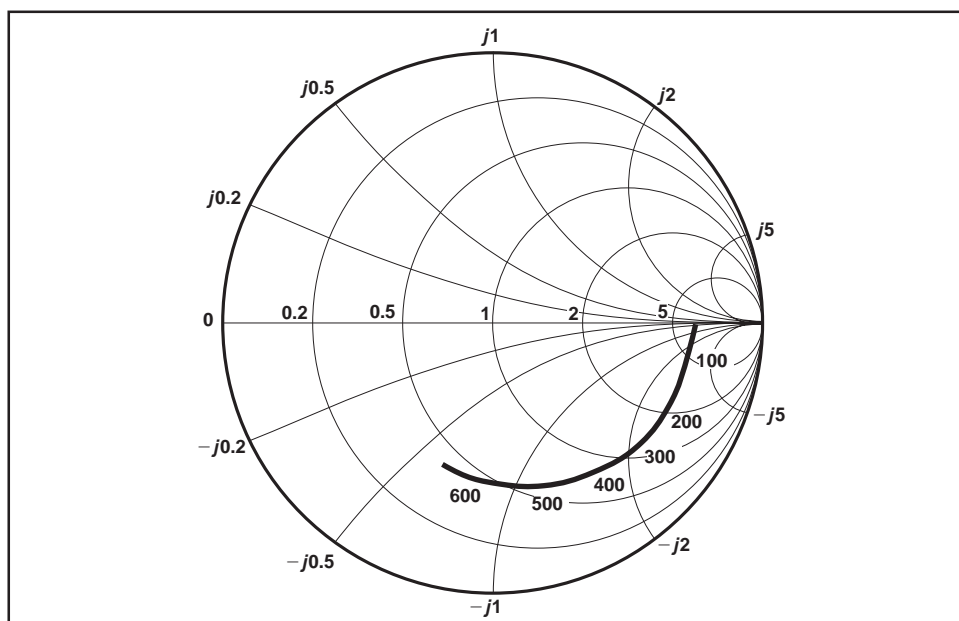

Fig. 5 Typical input impedance. Test conditions: Supply Voltage = 5V, Ambient Temperature = 25°C. Frequencies in MHz, impedances normalised to 50Ω.

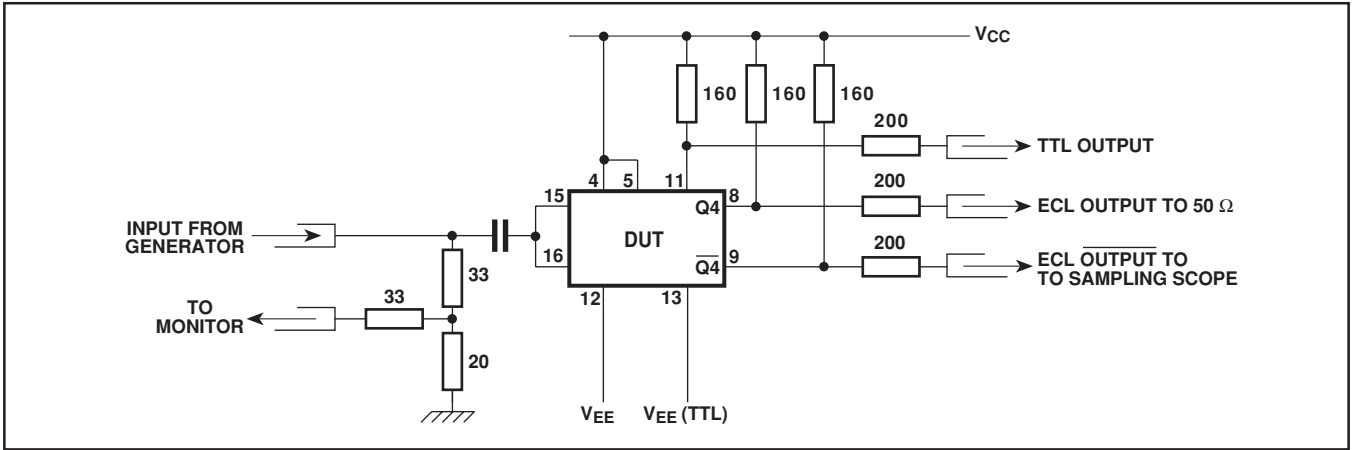

Fig. 6 Test circuit

OPERATING NOTES

1. The clock input, which is ECL10K compatible throughout the temperature range -55°C to $+125^{\circ}\text{C}$, can also be coupled to TTL as shown in Fig. 9. The clock can also be capacitively coupled to the signal source (see Fig. 7). Connecting the internally-generated bias voltage to the clock input i.e., pin 15 to pin 16, centres the clock input about the switching threshold (see Fig. 8).
2. The two complementary outputs are ECL10K compatible but internal pulldown resistors are not included and therefore external pulldown resistors to V_{EE} are required.

3. The TTL totem pole output operates with the same supply and is powered up by connecting V_{EE} (pin 12) to TTL V_{EE} (pin 13). If the TTL output is not required then the TTL V_{EE} pin should be left open circuit, reducing the power consumption by 20mW, typically.
4. Both control inputs (PE1 and PE2) are ECL10K compatible throughout the temperature range. Each control input is provided with a pullup resistor, the remote ends of which are connected to pins 6 and 7, respectively. This allows the pullup resistors to be unused if so desired or to be used to interface from TTL (see Fig. 9). If interfacing to ECL is required then pins 6 and 7 should be left open circuit; alternatively, they can be connected to V_{EE} to act as pulldown resistors. When high, the master set input sets the divider to the eleventh state, is asynchronous and overrides the clock input.
5. All the inputs have internal 50kΩ pulldown resistors.
6. The circuit will operate down to DC but inputslew rate must be better than $20\text{V}/\mu\text{s}$.
7. Input impedance is a function of frequency. See Fig. 5.

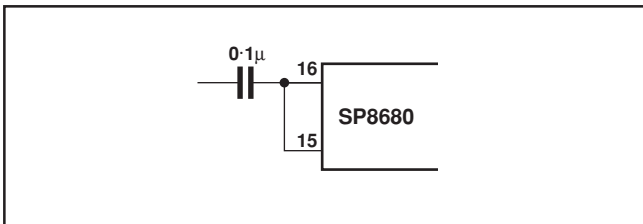

Fig. 7. AC coupled input

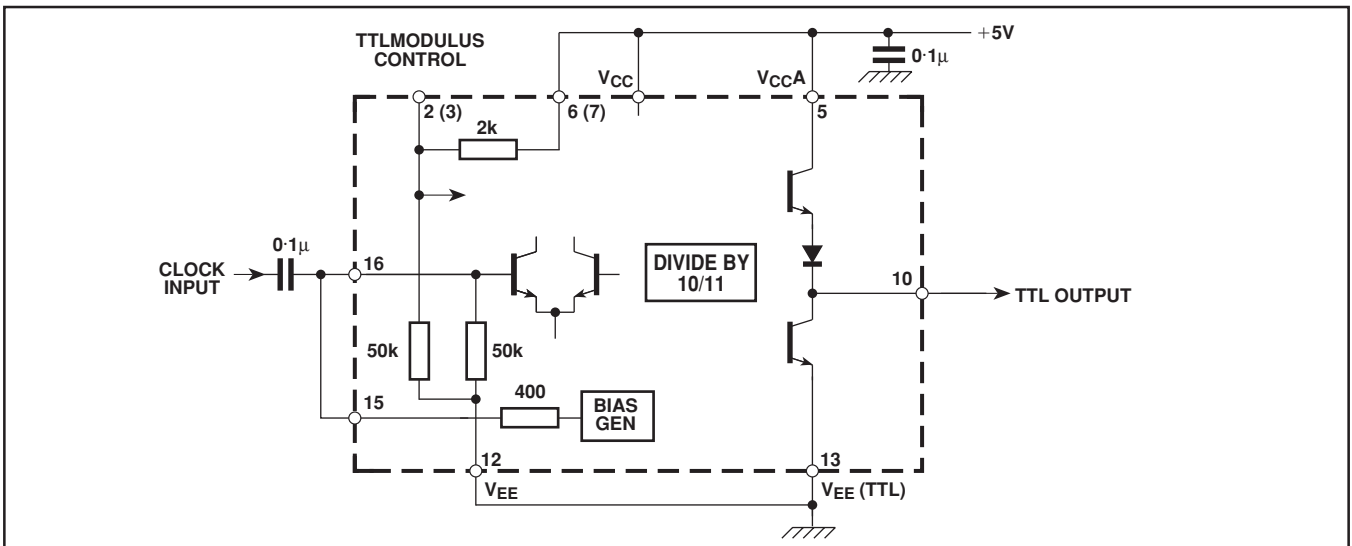

Fig. 8 Typical application showing TTL interfacing.

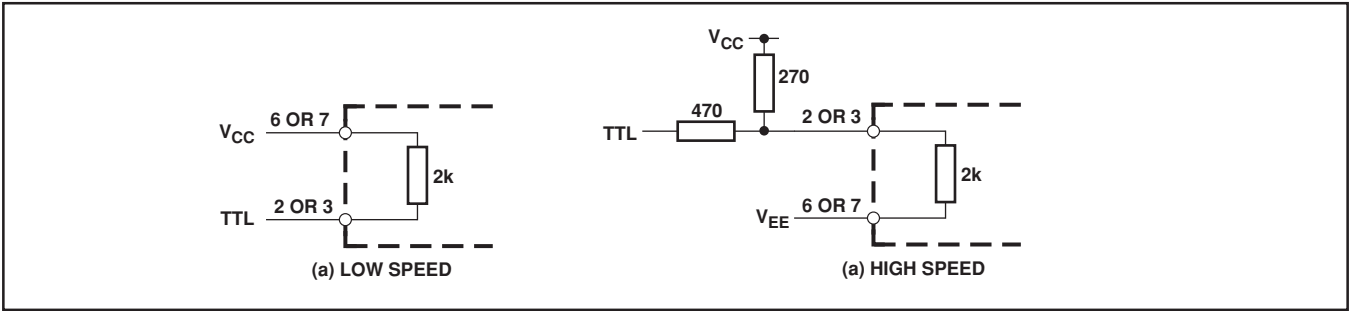
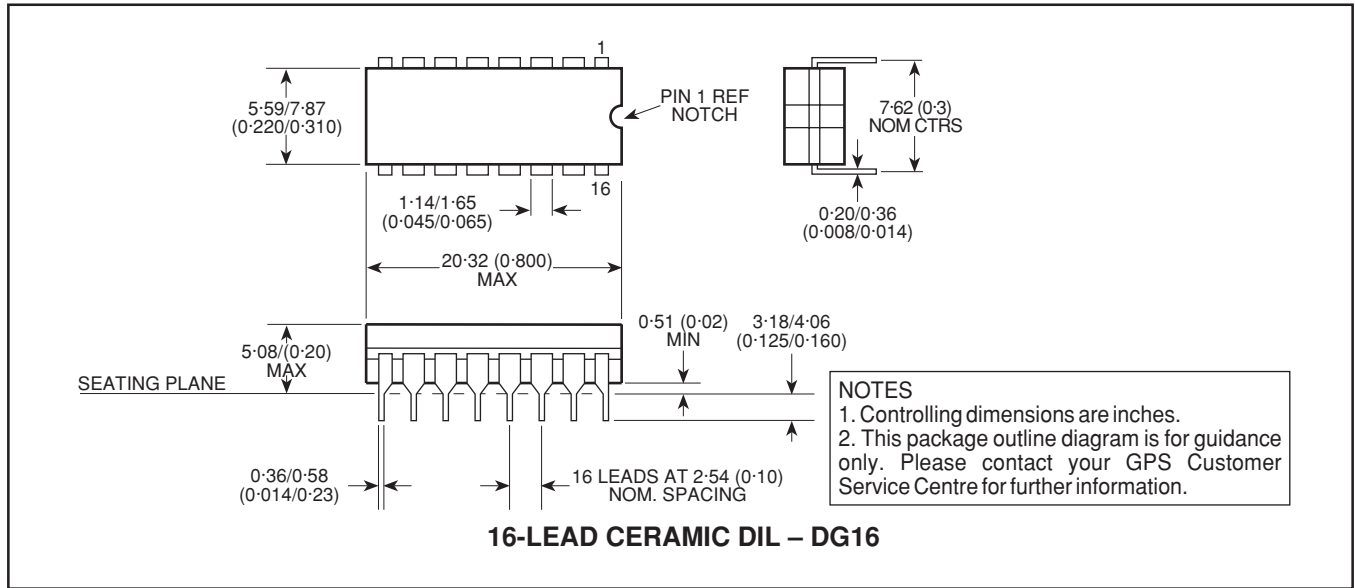

Fig. 9 TTL interface to PE1 and PE2

PACKAGE DETAILS

Dimensions are shown thus: mm (in).



HEADQUARTERS OPERATIONS
GEC PLESSEY SEMICONDUCTORS
 Cheney Manor, Swindon,
 Wiltshire SN2 2QW, United Kingdom.
 Tel: (0793) 518000
 Fax: (0793) 518411

GEC PLESSEY SEMICONDUCTORS
 P.O. Box 660017
 1500 Green Hills Road,
 Scotts Valley, CA95067-0017
 United States of America.
 Tel (408) 438 2900
 Fax: (408) 438 5576

CUSTOMER SERVICE CENTRES

- **FRANCE & BENELUX** Les Ulis Cedex Tel: (1) 64 46 23 45 Fax : (1) 64 46 06 07
- **GERMANY** Munich Tel: (089) 3609 06-0 Fax : (089) 3609 06-55
- **ITALY** Milan Tel: (02) 66040867 Fax: (02) 66040993
- **JAPAN** Tokyo Tel: (3) 5276-5501 Fax: (3) 5276-5510
- **NORTH AMERICA** Scotts Valley, USA Tel: (408) 438 2900 Fax: (408) 438 7023.
- **SOUTH EAST ASIA** Singapore Tel: (65) 3827708 Fax: (65) 3828872
- **SWEDEN** Stockholm Tel: 46 8 702 97 70 Fax: 46 8 640 47 36
- **UK, EIRE, DENMARK, FINLAND & NORWAY**
 Swindon Tel: (0793) 518510 Fax : (0793) 518582

These are supported by Agents and Distributors in major countries world-wide.

© GEC Plessey Semiconductors 1994 Publication No. DS3644 Issue No. 1.2 March 1994

This publication is issued to provide information only which (unless agreed by the Company in writing) may not be used, applied or reproduced for any purpose nor form part of any order or contract nor to be regarded as a representation relating to the products or services concerned. No warranty or guarantee express or implied is made regarding the capability, performance or suitability of any product or service. The Company reserves the right to alter without prior knowledge the specification, design or price of any product or service. Information concerning possible methods of use is provided as a guide only and does not constitute any guarantee that such methods of use will be satisfactory in a specific piece of equipment. It is the user's responsibility to fully determine the performance and suitability of any equipment using such information and to ensure that any publication or data used is up to date and has not been superseded. These products are not suitable for use in any medical products whose failure to perform may result in significant injury or death to the user. All products and materials are sold and services provided subject to the Company's conditions of sale, which are available on request.